



# Shimano BB

BB30/PF30/OSBB Conversion BB  
For SHIMANO HOLLOWTECH II Cranks

## SAFETY INFORMATION - READ BEFORE RIDE

Since specific tools and experience are necessary for proper installation, it is recommended that the product be installed by a qualified bicycle technician.

Read the service instructions of your crank carefully prior to installing the parts. Loose, worn or damaged parts may cause riding problems and serious injury may occur as a result. If installation and adjustments are not carried out correctly, the chain may come off and this may cause you to fall off the bicycle which could result in serious injury. **Read these instructions carefully, and keep them for later use.**

- Ensure that your BB30/PF30 frame shell is clean. If a BB30 frame, remove the c-clips/bearings so frame shell is empty.
- Conversion BB - Make sure the black O-ring is on the Non-Drive Cup prior to pressing into Non-Drive side.
- Apply **Anti-Seize** to the drive cup threads and smooth taper area before installing.
- Before riding the bicycle, check that there is no play or looseness in the bottom bracket connection. Also, be sure to retighten the crank arms and pedals at periodic intervals.
- If you feel any looseness or 'play' in the bearings, the bottom bracket should be inspected/replaced.
- Be sure to read the instructions for your front chainrings/crank in conjunction with these service instructions.
- **Do not wash the bottom bracket with high-pressure jets of water.**
- For maximum performance it is required to remove and periodically inspect/clean your Praxis Works bottom bracket.
- **Parts are not guaranteed against natural wear or deterioration resulting from normal use.**
- For any questions regarding methods of installation, adjustment, maintenance or operation, please contact a professional bicycle dealer or call Praxis Works.
- Praxis Works assumes no responsibility for damages or injury related to improperly installed components.

**READ THE STEP BY STEP INSTRUCTIONS PROVIDED ON THE OTHER SIDE.**

## WARRANTY

- Praxis Works Bottom Bracket products are warranted to be free from defects in materials or workmanship for two years after original purchase. The warranty is non-transferable and valid to the original purchaser of the product only.
- Any attempt to modify the product in any way such as drilling, grinding or painting will void the warranty.
- This warranty is not valid for "abused" or neglected products, or products that are damaged by improper installation.
- If a defect is found, our entire liability and your sole remedy shall be, at our option, free repair or replacement of the Praxis product.
- Except as expressly required by law, Praxis Works shall not be held liable for any indirect, special, or consequential damages.

THIS WRITTEN EXPRESS WARRANTY IS IN LIEU OF ALL OTHER WARRANTIES, IMPLIED OR EXPRESSED. This warranty gives you specific legal rights, and you may also have other rights which vary state to state. **For more information on warranty policy and instructions for completing a warranty claim, check out the Full Warranty Policy found at our website. [www.praxis-works.com](http://www.praxis-works.com)**

Note: specifications are subject to change without notice. © July 2016 by Praxis Works,

## Shimano Conversion BB

### BB30/PF30/OSBB Compatibility and Spec

CRANKSET	Compatible with SHIMANO HOLLOWTECH II <b>68mm for ROAD Cranks only - 73mm for MTB Cranks only</b>
FRAME SHELL	Only for BB30, PF30, and Specialized OSBB frames 68mm or 73mm
FRONT DERAILLEUR	Braze-on, ST Clamp, or Direct Mount. No E-Type or BB Mounted Guides

### REQUIRED TOOLS

- Headset Press Tool
- Two Shimano BB Tools
- Headset cup removal tool
- Anti-Seize Compound
- Waterproof Grease

### Included Delrin Sleeve for PF 30 Frames



Included Parts		
Number	Part	Qty
1	Compression O-Ring	1
2	Compression Sleeve	1
3	Drive Side (RH) Cup 24mm ID Bearing	1
4	Shimano Bearing Cover	1
5	Shimano Bearing Cover	1
6	Non Drive Side (LH) Cup 24mm ID Bearing	1
7	Tolerance O-Ring	1

**Drive Side**

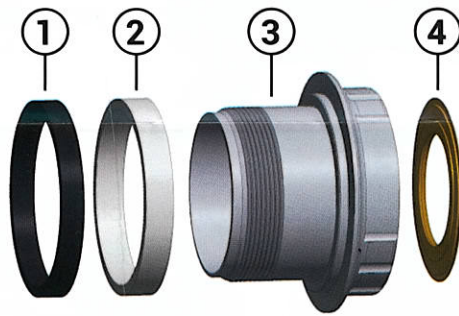

**Non-Drive Side**

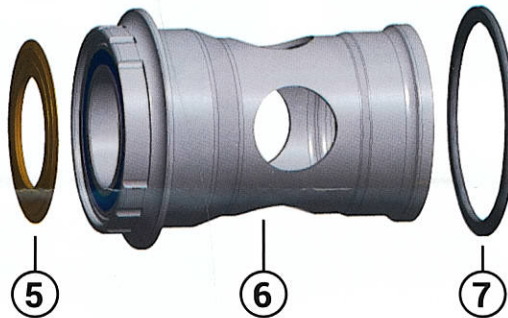

## 1. PREP

### Non-Drive/LH CUP FOR OSBB AND BB30/PF30

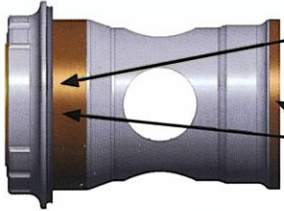

- 1 Slide Tolerance O-ring onto LH Cup. This is required to accommodate frame width variances.
- 2 Apply thin coating of ANTI-SEIZE to both ends of the BB cup. (Use Grease for PF30 Installation)



← Slide Sleeve on for PF30

### FOR PF30 ONLY

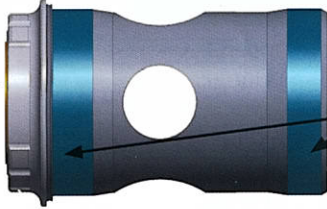

- 3 Slide PF Sleeve onto LH Cup until it just presses against the the Tolerance O-ring.
- 4 Apply thin coating of GREASE to both ends of the PF Sleeve.

### Drive/RH CUP FOR OSBB AND BB30/PF30

- 1 Apply thin coating of GREASE to the RH cup.
- 2 Apply thin coating of ANTI-SEIZE to the RH cup threads.
- 3 Slide the Rubber Compression O-ring and Plastic Compression Sleeve onto the cup with the **Compression Sleeve first**. This is critical to the function of your BB.
- 4 Apply GREASE to the [unclear] and [unclear]

2<sup>nd</sup>

1<sup>st</sup>

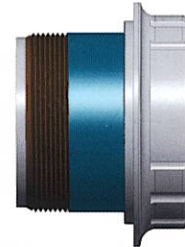

(Rubber)

(Plastic)

## 3. TIGHTEN

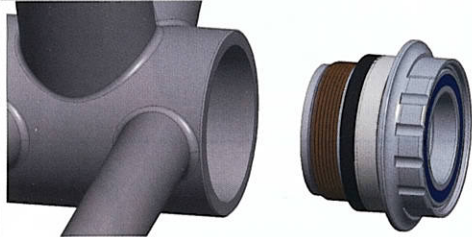

- 1 Start threading the Drive Cup in **CLOCKWISE** with your Shimano BB tool. As it threads in, you will feel friction build as the compression o-ring expands against the frame. **This is normal. Grab your 2nd BB tool at this point.**

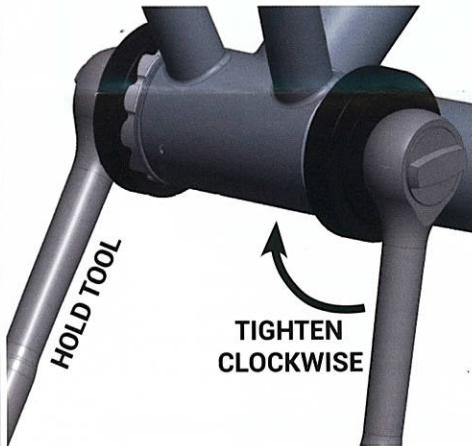
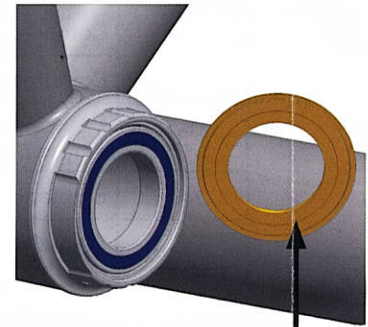

- 2 **TURN THE DRIVE CUP UNTIL IT STOPS**  
With 2nd BB tool, hold the Non-Drive firm while you tighten down the Drive cup. This gives you leverage and allows you to feel when the Drive cup bottoms out on the Non-Drive cup.  
*The Drive Cup has a machined stop and by design it **MUST** be tightened until it bottoms out on the Non-Drive cup.* This precisely sets/stops the collet expansion.

- 3 Dab some grease on the underside of the included Outer Seals, then place them over the bearings with the **Praxis wordmark facing outward**.

- 4 The Shimano Conversion BB install is now finished. Install your crank using the instructions included with your crank.

## 2. PRESS

### OSBB SLEEVE INSTALL

- 1 Remove stock bearing assembly and **completely clean** any residual glue, grease, or other debris from BB shell.
- 2 Spread a *thin* layer of grease on the outside of the OSBB Sleeves.

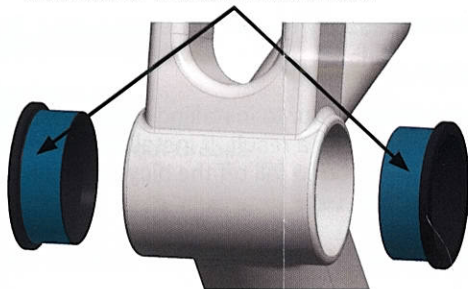

- 3 Press each cup *individually* using the headset press. **Cups must be flush to the frame** before installing the BB.

### CONVERSION BB INSTALL

With a press tool, **GENTLY** press the Non-Drive cup into the Non-Drive side of frame so the Tolerance O-ring just **BARELY** touches the side of frame.

**DO NOT COMPRESS THE TOLERANCE O-RING.**

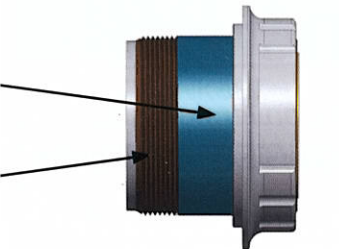
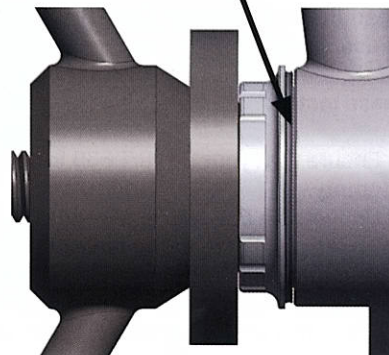

- 4 Apply thin coating of **GREASE** to the outside of the Compression O-ring and Compression Sleeve.

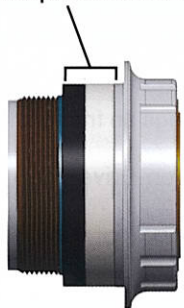

## REMOVAL

- 1 Unscrew the Drive Cup **COUNTER-CLOCKWISE** and remove along with the Compression O-ring and Compression Sleeve. **Use one tool to hold the Non-Drive side for leverage, and the other to unscrew the Drive cup.**
- 2 Once the Drive Cup is removed, slide a headset cup removal tool through from the drive side and it will catch outside edge of the Non-Drive cup.



- 3 Carefully bracing the tool/frame, very gently hammer/tap the removal tool to push the Non-Drive Cup out of frame. *We recommend using a 1.5" headset cup removal tool as it has a wider stance.*

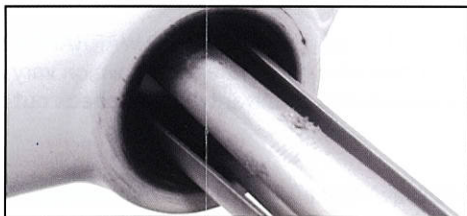

ne  
led  
e  
s with  
acing

k